

2014

Wireless sensor networks mobility management using fuzzy logic

Zinonos, Zinon

Elsevier

<http://hdl.handle.net/11728/10219>

Downloaded from HEPHAESTUS Repository, Neapolis University institutional repository



Wireless sensor networks mobility management using fuzzy logic



Zinon Zinonos^a, Chrysostomos Chrysostomou^b, Vasos Vassiliou^{a,*}

^a Computer Science Department, University of Cyprus, 1 University Ave., 2019 Nicosia, Cyprus

^b Department of Computer Science and Engineering, Frederick University, 7 Y. Frederickou Str. Pallouriotissa, 1036 Nicosia, Cyprus

ARTICLE INFO

Article history:

Received 4 January 2013
Received in revised form 2 July 2013
Accepted 5 December 2013
Available online 26 December 2013

Keywords:

Wireless sensor networks
Mobility
Handoff control
Performance control
Fuzzy logic
Industrial evaluation

ABSTRACT

This paper presents a novel, intelligent controller to support mobility in wireless sensor networks. In particular, the focus is on the deployment of such mobility solution to critical applications, like personnel safety in an industrial environment. A Fuzzy Logic-based mobility controller is proposed to aid sensor Mobile Nodes (MN) to decide whether they have to trigger the handoff procedure and perform the handoff to a new connection position or not. To do so, we use a combination of two locally available metrics, the RSSI and the Link Loss, in order to “predict” the End-to-End losses and support the handoff triggering procedure. As a performance evaluation environment, a real industrial setting (oil refinery) is used. Based on on-site experiments run in the oil refinery testbed area, the proposed mobility controller has shown significant benefits compared to other conventional solutions, in terms of packet loss, packet delivery delay, energy consumption, and ratio of successful handoff triggers.

© 2013 Elsevier B.V. All rights reserved.

1. Introduction

In recent years, applications of sensor networks have evolved in many areas due to their large applicability and development possibilities, especially in the Wireless Sensor Networks (WSN) area. Research on WSN has mainly been focused on protocols and algorithms for applications, in which large, random, and static deployment is the norm and in which node mobility and network performance assurances are not considered critical. In addition to the diverse applications, sensor networks pose a number of unique technical challenges because of their ad hoc deployment, unattended operation, and dynamic changes. Most sensor applications need the deployment to be infrastructure-less, without any human intervention. It is the responsibility of the sensor network to be adaptable to any physical changes like the addition of extra nodes or

the failure of a number of them. In addition, there is only a finite source of energy, which must be optimally used for processing and communication. Nowadays, several application sectors like healthcare, industrial automation, urban sensing/computing, and vehicular sensor networks assume and incorporate the use of MN, usually in direct connection (one hop) from the data collection point (sink). However, it is expected that, in the near future, node and network mobility will become common for wireless sensor networks as well. In addition, in spite of the potential of WSNs, real deployments are rare and virtually all have considerable limitations when user mobility is concerned. These limitations include, among others, the need of extra hardware like directional antennas or GPS, and/or the existence of positioning methods. These solutions are difficult to provide the expected results in the case of harsh environments due to the propagation model characteristics arising from the physical environment [1]. Furthermore, the majority of the existing solutions are based on simulation results, something that usually denotes a mismatch between research and reality.

* Corresponding author. Tel.: +357 22892750; fax: +357 22892701.

E-mail addresses: zinonos@cs.ucy.ac.cy (Z. Zinonos), ch.chrysostomou@frederick.ac.cy (C. Chrysostomou), vasosv@cs.ucy.ac.cy (V. Vassiliou).

Mobility support in this work has been mainly motivated by the need to monitor the health and status of mobile workers in industrial settings. There are many hazardous activities in an industrial plant that need to be monitored for safety. One such activity is the cleaning and condition assessment of storage tanks in an oil refinery. Tanks are very hazardous environments and typically contain a toxic atmosphere and residues of their previous contents. When employees enter such hazardous areas there is a possibility to loose consciousness. Using orientation and heart or pressure monitoring sensors attached to employees, their condition can be monitored and alarms can be signaled when an emergency occurs. Surrounding the tank that is being cleaned are usual sensors deployed for other scenarios, e.g. production monitoring. As the mobile worker moves around the tank, orientation messages are sent from the sensor to the sink forwarded by intermediate nodes. Data may be sent via different intermediate nodes based on the location of the mobile worker. In order to continuously receive information from the mobile workers a mobility management technique must be implemented so as to enable the handoff between different access points, while at the same time maintaining strict performance guarantees for the critical application.

Supporting mobile nodes in an industrial environment is something that the existing industrial standards like WirelessHart [2,3] and ISA100 [4] do not give special attention to. WirelessHART and ISA100.11a use a centralized network management approach for communication scheduling and managing routes. Despite the advantages of such approach when the network topology and application requirements are static and heavily pre-configured, it is not certain how these standards perform in dynamic situations involving node mobility. The inability to properly handle mobility may result in problems, including increased packet loss, delayed data delivery, and increased downtime, all of which increase the overall energy consumption.

The uniqueness of this work is threefold. Firstly, an intelligent controller, based on fuzzy logic is proposed. This controller enables sensor MN to decide intelligently whether they have to trigger the handoff procedure and perform the handoff to a new position or not. Secondly, a real industrial setting (oil refinery) is used as the evaluation environment, something that poses new challenges regarding the design of mobility support. Thirdly, the approach taken has greater applicability to any WSN industrial environment or testbed setting with mobility requirements, due to the fact that it was designed based on network state parameters that are available to all sensor MN. The selection of fuzzy logic system was based on its simplicity and the fact that, since it processes experts-defined rules governing the target control system, it can be modified to improve system performance.

The overall system was implemented and evaluated in the context of the EU-funded GINSENG project [5,6]. The end user of the project was the company operating the Petrogal oil refinery at Sines, Portugal. The Petrogal refinery is a complex industrial facility, which includes a wide range of processing units that need careful monitoring and control of critical operations. Currently, the refinery is

completely automated, but totally wired-based. Upgrades to the current wired system are impossible to perform in order to support mobile users. Therefore, a real WSN has been deployed in the refinery, targeting several specific scenarios including the monitoring of mobile workers (personnel safety scenario). Finally, to the best of our knowledge, GINSENG is the only work that considers the use of MN inside an industrial area.

The paper is organized as follows. In Section 2 background information and related work are presented and in Section 3 the basic methods for handoff control in industrial WSNs are discussed. Section 4 examines the proposed fuzzy logic-based mobility approach. In Section 5 the experimental evaluation and performance analysis are presented and, finally, in Section 6 the conclusions of this work are offered.

2. Background and related work

In critical applications, like personnel safety in an industrial environment, a real-time monitoring system must always be available. In order to efficiently monitor or control a mobile person moving in a WSN area, the mobile entity must be able to handoff between different supporting/anchoring nodes or networks while performing its movement. Therefore, the existence of a proper mobility protocol to control the handoff procedure is required.

Several proposals have appeared in the literature that attempt to control and accelerate the handoff procedure. These proposals can be classified based on the protocol stack layer the information they use to handle mobility belongs to. Therefore, there are solutions that are based on the Network Layer and solutions that are based on the MAC sub-layer of the Data Link Layer.

2.1. Network-based mobility handling

Internet Protocol (IP) mobility can be approached from three points of view: the first one, and also the most common solution, is to deal with the handoff procedure locally at the Network Layer of the mobile entity (MIPv6 [7], HMIPv6 [8]). The second approach uses information from Data Link Layer to speed up the handoff process (FMIPv6 [9]), and the third solution is based on a non-invasive method known as network-based mobility (PMIPv6 [10]). Even though, the aforementioned solutions were not designed for sensor networks, some of their characteristics can be used in a WSN mobility solution. In addition to that, some effort was done to integrate the Internet Protocol with the WSN [11] so that to exploit the benefits offered by the use of the IP protocol. The IETF 6LoWPAN [12] working group performed the most significant effort to this direction. The challenge for IP integration is to find ways to manage and overcome the limitations posed by sensor networks, like low power consumption, low duty cycles, low memory, and limited bandwidth. Some approaches to support mobility in 6LoWPAN have been defined. In general, those approaches [13–19] are lightweight extensions of IPv6 based solutions (MIPv6, HMIPv6, FMIPv6, PMIPv6). The main target of these approaches is to com-

press the information exchanged between the MN and routers. Although they achieved this target, the main drawback is that the MN is involved in all the functionalities and signaling of the mobility protocol something that increase the energy consumption. Thus, a new approach [20] has been defined where the use of Proxy Mobile IPv6 is considered. The advantage of this approach is the fact that the MN does not require to support any mobility related functionality, since those are assigned to a new entity, called Proxy Agent. In [21] an overlay proxy-based solution is proposed in order to support MNs mobility signaling using both intra- and inter-mobility scenarios so that to lessen the involvement of the MN to the handoff event. To the best of our knowledge, none of the above solutions have been implemented and evaluated in a real testbed. Finally, all of the above 6LoWPAN mobility solutions assume the solely use of Received Signal strength in order to support the handoff decision procedure.

2.2. MAC-based mobility handling

The majority of the MAC protocols for WSNs support the introduction and failure of nodes (weak mobility) in the topology. For example, TDMA protocols like SMAC [22] and TMAC [23] exchange packets in order to learn their neighbors. On the other hand, contention-based protocols like BMAC [24] and XMAC [25] recognize changes by sending a burst of preambles. Despite that, since the changes in the topology are observed at the beginning of each active period this leads to an increase in the delay of the packet transmission. A mobile node introduces several challenges in the MAC protocols like increase of the collisions in case of contention-based protocols and scheduling issues in case of TDMA protocols. Examples of mobility-aware MAC protocols for WSN solutions that are related with this work are the MS-MAC [26], MA-MAC [27] and MobiSense [28]. MS-MAC is the mobility extension of contention-based SMAC protocol and it tracks the Received Signal Strength Indicator (RSSI) values from SYNC messages to identify the movement of a node. MA-MAC is an extended version of XMAC in which the node sleeps most of the time and switch on periodically the radio for receiving the incoming packets. MA-MAC detects mobility through the RSSI value of ACK packets during communication and switches from unicast to broadcast to interleave data communication with neighbor discovery. In MobiSense, nodes are organized into clusters, in which static nodes act as cluster heads and MN move between them. The MN listen to synchronization packets sent by cluster heads and decide to join the network or handoff from one cluster to another. The common characteristic of the above solutions is the solely use of RSSI value to characterize the link quality.

2.3. Triggering the handoff

In general, the handoff procedure is initiated by a triggering decision. The handoff triggering is usually based on parameters like the RSSI or the Packet Reception Rate (PRR). The main issue of using individually those metrics is the unpredictable behavior and the rapid fluctuations

of the wireless medium, especially inside an industrial environment. In the literature, several approaches have been proposed [29,30] that make use of RSSI either as a single decision method or supported by a threshold and/or hysteresis margin methods. Using the first method the mobile node will handoff whenever it receives a better RSSI from a new attachment point. Besides its simplicity this method causes unnecessary handoffs because it does not consider the quality of the current link but only that there is a new link with a better RSSI. In order to solve this issue a threshold value was added, where the mobile node will handoff only if the current RSSI of the link is below a predefined threshold and there is a new attachment point with better RSSI. The hysteresis margin can be added in both aforementioned methods so that to avoid the ping-pong effect. The issue with hysteresis margin is that the correct value must be selected based on the specific operation environment so as to minimize the probability of delaying the handoff procedure.

The importance of the RSSI metric as a quality indicator was argued in [31] where the authors have shown that generally for RSSI values greater than -87 dBm the resulting PRR is at least 85% indicating a very good link. In addition, they have shown that RSSI is a promising indicator when its value is above the sensitivity threshold of the radio communication chips (in their case the CC2420 chip). Finally, they concluded that protocol designers looking for inexpensive and agile link estimators may choose RSSI over the Link Quality Indicator (LQI).

In [32] the authors measure the wireless link burstiness and they conclude that if the mean received signal strength (RSS) is above -80 dBm then the link is almost always good. An exception to this value occurs when people were actively moving between the nodes, in which case there is a gray region of good, intermediate, and poor links slightly below the identified -80 dBm threshold.

In [33] the authors performed a set of experiments to get a better understanding of key parameters, namely, the lower link quality threshold level and the hysteresis margin. They conclude that the network perform best when the lower link quality threshold is equal to -90 dBm and the hysteresis margin is equal to 5 dBm.

In [28] the authors proposed a handoff scheme in which a mobile node constantly monitors the received power from its cluster-head and it triggers a handoff decision when the RSSI drops below a power threshold of -75 dBm. Authors justified this value based on previous studies which found that such threshold can guarantee packet reception ratios above 95% [34,35].

Based on the aforementioned related work the RSSI threshold value varies from -90 dBm to -75 dBm depending on the evaluation environment and on the targeted PRR.

Some research works [36,37] propose the use of heuristic models, like fuzzy logic, to support the handoff triggering decision. In [37] authors provide a fuzzy logic system to support the mobility procedure based on the RSSI level, the velocity of the mobile node, the number of hops to the sink node, and some other metrics such as traffic load, energy level, and link quality value. Even though the proposed solution was discussed in detail, there was no

implementation or evaluation of it. Therefore, the applicability of the solution and any possible overhead are undetermined. In addition, the high number of metrics that they aim to use will, undoubtedly, lead to an increased complexity of the fuzzy logic system, since a big number of rules must be enabled at any time. Due to the limited capabilities of the sensor nodes a fuzzy logic-based system must be as simple as possible.

Several works using fuzzy logic techniques have appeared in the field of mobility management, with the majority targeting the support of vertical handoffs. In [36], a handoff decision for heterogeneous networks is identified as a fuzzy multiple attribute decision-making problem and fuzzy logic is applied to deal with the imprecise information. In [38], a handover algorithm is proposed to support vertical handovers between heterogeneous networks. This is achieved by incorporating the mobile IP principles in combination with fuzzy logic concepts utilizing different handover parameters. Furthermore, in [39], the authors deal with a vertical handover decision algorithm based on the fuzzy control theory. The algorithm takes into consider the factors of power level, cost, and bandwidth in order to decide about the vertical handover. In [40,41], the authors proposed and implemented a Fuzzy-Based Handover System (FBHS), where they showed that the proposed system had a good behavior for handover enforcement, but in some cases could not avoid the ping-pong effect.

In this work we propose a fuzzy-based solution that does not change the existing conventional algorithms, but uses operations of them in order to provide a system that will manage to control the handoff procedure and provide improved performance. The selection of the fuzzy logic method was based on its simplicity and the fact that since it processes experts-defined rules governing the target control system, it can be modified and tweaked easily to improve or drastically alter system performance.

Analysis of the state of the art in this area reveals that there are a whole raft of projects and initiatives covering a wide spectrum of related research challenges, technological problems and collaboration activities in Mobile Wireless Sensor Networks. However, the motivation of this work is the fact that there is no protocol designed and evaluated to support the mobility process in critical environments; thus, this work provides effective solution to this missing piece. This issue is considered of the utmost importance for today's real-world industrial applications.

3. Handoff control in industrial WSNs

This section presents the drawbacks of the RSSI Threshold-based solution and outlines the design requirements for schemes involving fuzzy-based logic.

3.1. RSSI threshold-based handoff decision

Prior work by Zinonos [42] and Silva [43] has used RSSI threshold as a handoff control method in critical application scenarios, including industrial cases. Based on the referenced works, the handoff decision rule used was: *If the*

RSSI of the communication link between the MN and the current parent is below a predefined threshold H then the MN will trigger a handoff. This option was named *RSSI Threshold handoff*. The RSSI information is available at the frame header of every packet that is transmitted. An example of the behavior of the RSSI parameter during a random walk in the refinery environment is shown in Fig. 1.

The suitability of the RSSI in an industrial environment was argued and used in [31], using a moving average calculation of the RSSI (average of at least 100 measurements) in order to minimize the RSSI drop effect and to make the behavior of the RSSI smoother. However, in the experiments performed in this work a moving average solution could not be directly applied, since the target user was mobile and there was no time for taking the average of a number of measurements before initiating a handoff. Another drawback of the RSSI threshold solution is that it has an end-to-end packet loss rate that is very high by any standard. According to [44,45] acceptable values for end-to-end packet loss are between 1% and 3%.

3.2. Fuzzy-based handoff decision

Due to the limitations of the sensor nodes a good protocol design approach is to pursue a method in which the mobility support solution should use, as much as possible, existing information, in order to avoid any overhead to the system. Any new functionality needed can be considered if the overhead added to the existing system is negligible. In addition, to provide a distributed solution, meaning that no central entity exists that has full knowledge of the system and decides about the handoff procedure, no centralized collection and dissemination of important metrics is considered. Therefore, all the information that is used is locally available at each node and no communication overhead is added.

To support the handoff procedure one could additionally select the percentage of frames lost at the link from the mobile node to the first static node serving as its anchor in the network. This will be called *Link Loss* in the rest of this paper. Link Loss denotes the ability of the MN to

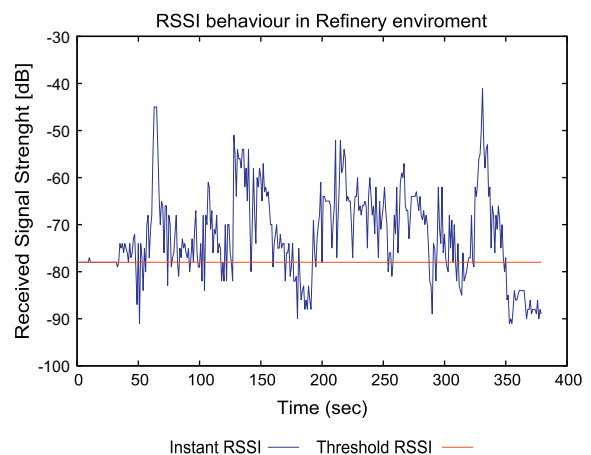

Fig. 1. RSSI behavior in the refinery testbed.

communicate successfully directly with the parent node considering also any retransmissions at the MAC layer. In addition, link loss is locally available at each node.

A second set of experiments was performed in the testbed area to extract information regarding the relationship of the end-to-end losses, RSSI and link losses. The reason of not directly using end-to-end packet loss is that this information is not available at each node but only at the end system (sink node). Therefore, the value of the end-to-end loss needs to somehow be predicted using other metrics that are available to each node. The results of those experiments are shown in Fig. 2. Based on the results, it can be concluded that a combination of RSSI and Link Loss can be related to end-to-end losses and support the hand-off triggering procedure.

Fig. 2 shows that, in the testbed under evaluation, when the link loss is above 15% and the RSSI is less than -78 dBm, the end-to-end packet loss is substantial and, obviously, not acceptable. Another conclusion is that when the RSSI is relatively good (greater than -60 dBm) and the link loss is up to 40%, the end-to-end packet loss is acceptable. This behavior is due to the ability of the mobile node to retransmit the packets in case the communication link between the MN and the parent node is good.

In order to exploit the conclusions reached above, Fuzzy Logic (FL) techniques can be used. The reasons for selecting Fuzzy Logic are:

- It has the ability to control nonlinear systems based on observable phenomena.
- It provides the opportunity to easily modify the experts-defined rules and tune the membership functions so that to achieve the desired performance. In other words, fuzzy logic can be flexible.
- It can be built based on the experience of people who already understand the system. Therefore, it needs no training and learning procedures like other solutions (e.g., neural networks).

Fuzzy logic control (FLC) [46] is a logical system that belongs to the family of tools of what is commonly known as computational intelligence (CI). The concept of FLC was ini-

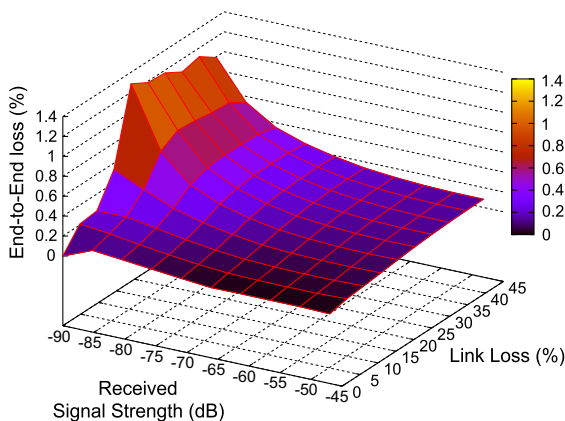

Fig. 2. End-to-End loss, Link Loss and RSSI relation.

tially conceived by [47] in 1965 and first applied by [48] in an attempt to control systems that are difficult to model mathematically or are too complex and possibly highly nonlinear (e.g. in communication networks [49,50]).

The main feature of FL is the ability it has to qualitatively detect the characteristics of a control system based on observable phenomena. During the last decade, FLC has been demonstrated in a plethora of applications, research projects, and commercial products. The idea behind the usage of FLC is to avoid the limitations that arise from complex systems parameters introduced to mathematical models. To do so, the fuzzy logic system must be designed and implemented with intuitive understanding of the system to be controlled. Therefore, FLC concentrates on attaining an intuitive understanding of the way to control the process, incorporating human reasoning in the control algorithm. It is independent of mathematical models of the system to be controlled. It achieves inherent robustness and reduces design complexity. This is in contrast with conventional control approaches that concentrate on constructing a controller with the aid of an analytical system model that in many cases is overly complex, uncertain, and sensitive to noise.

In order to create a fuzzy control system a specific procedure must be followed. This procedure involves identifying and naming the fuzzy inputs and outputs, creating the fuzzy membership functions for each, constructing the rule base, and deciding how the action will be carried out. The input/output variables in a fuzzy control system are in general mapped into fuzzy sets. The process of converting a crisp input value to a fuzzy value is called “fuzzification”, where “defuzzification” is a mapping from a space of fuzzy control actions defined over an output universe of discourse into a space of non-fuzzy (crisp) control action. A fuzzy set is defined by a membership function that can be any real number in the interval $[0,1]$, expressing the grade of membership for which an element belongs to that fuzzy set.

4. Fuzzy Logic-based Mobility Controller – FLMC

The Fuzzy Logic-based Mobility Controller (FLMC) is designed to enable any wireless sensor MN to decide intelligently whether the handoff procedure has to be triggered. The approach taken has greater applicability to any WSN industrial environment or testbed setting with mobility requirements, since it is designed based on network state parameters that are available to all wireless sensor MNs.

A simple fuzzy inference engine (FIE) is designed to operate locally at each sensor MN, and control the handoff decision procedure, using linguistic rules that describe the behavior of the environment in differing widely operating conditions. The FIE implements a nonlinear decision probability (to trigger the decision whether a sensor mobile node has to handoff to a new position or not), and uses feedback from the instantaneous value of the signal strength indication (RSSI) and the Link Loss rate, both sampled periodically. By having a nonlinear control law, based on fuzzy logic, the aim is to effectively deal with the high variability and dynamics appearing in the network, and

thus exhibit fast system response and robust behavior in spite of varying network conditions. Thus, a nonlinear control law is more efficient to cope with these uncertainties and dynamics, in contrast with a linear control method.

There is no accepted systematic procedure to design a fuzzy controller [46]. The most commonly used approach is to define membership functions of the inputs and output based on a qualitative understanding of the system, together with a rule data base, and to test the controller by trial-and-error until satisfactory performance is achieved. More sophisticated techniques abound, however, we opt for this simple approach which also yields a simple implementation, and as we show later it is quite effective. We rely on the use of heuristic expertise and study of the plant dynamics about how to best configure the control law. The main focus is on the achievement of the mobility requirements indicated in Table 2 – Section 5.1, whilst keeping the design of the controller as simple and generic as possible. Thus, concerning the limitations that arise from sensor networks, this method seems to be a suitable approach for our system. Note that as the fuzzy controller is nonlinear, it is very difficult to examine analytically the influence of certain parameters. Usually, extensive simulation and experimentation are used to investigate its behavior. However, a systems stability technique is followed (more later, – Section 5.5) that verifies that the states of the system remain within specific bounds.

Our aim is to ensure that the controller will have the proper information available to be able to make good decisions, and will have proper control inputs to be able to steer the controlled system in the directions needed, so that it achieves a high-performance operation, as pointed out above. Some of the design choices are briefly described below.

4.1. Selection of input–output and scaling

Since multiple inputs can usually capture the dynamic state of the controlled system more accurately, and can also offer the ability to linguistically describe the system dynamics [46], we utilize a two-input, single-output (simplest of the Multiple Input Single Output (MISO) model) fuzzy controller on each sensor MN in WSNs. There is a need to choose the right inputs and output with generic normalized universe of discourse, applicable in any setting. We select the RSSI and the Link Loss, two locally available metrics, in order to “predict” the End-to-End losses and

support the handoff triggering procedure. The influence of these two metrics on attempting to predict the End-to-End loss was shown and discussed in Section 3.2 (also, see Fig. 2). Furthermore, the output of the controller is selected as a nonlinear decision probability that is given as input of the controlled system in order to decide whether to trigger a handoff procedure. After all the inputs and the output are defined for the proposed FLMC controller, we specify the fuzzy control system shown in Fig. 3, where all quantities are considered at the discrete instant kT :

1. T is the sampling period.
2. $RSSI(kT)$ is the signal strength indication, taken every sampling period.
3. $LL(kT)$ is the link loss rate measured at each sampling period.
4. $Pd(kT)$ is the calculated decision probability that triggers the handoff procedure.
5. $SG_{i,2}(kT)$ are the input scaling gains.
6. $P_{Threshold}$ is a predefined threshold that indicates if the specific $Pd(kT)$ will trigger the handoff.

In fuzzy control theory, the range of values of inputs or outputs for a given controller is usually called the “universe of discourse”. Often, for greater flexibility in fuzzy controller implementation, the universe of discourse for each process input is “normalized” by means of constant scaling factors [46]. For the fuzzy controller design developed here, the input scaling gains, $SG_{i,2}(kT)$, are inherently chosen so that the range of values $SG_{i1}(kT)$ $RSSI(kT)$ and $SG_{i2}(kT)$ $LL(kT)$ lie in the real interval $[0, 1]$ (see Eqs. (1) and (2)).

$$SG_{i1}(kT) = \frac{1 - \frac{RSSI_{min}}{RSSI(kT)}}{RSSI_{max} - RSSI_{min}} \tag{1}$$

$$SG_{i2}(kT) = \frac{1}{100} \tag{2}$$

where $RSSI_{min}$ and $RSSI_{max}$ were obtained during the experiments conducted in the setup phase of the oil refinery testbed.

4.2. Selection of rule base, linguistic variables and values

The multi-input FIE uses linguistic rules to calculate dynamically the decision probability. These linguistic rules form the control knowledge rule base of the controller and

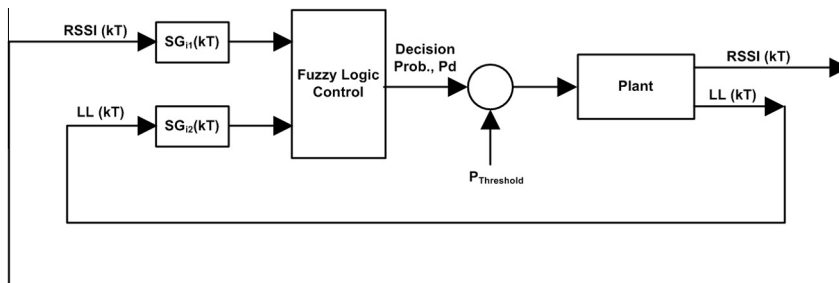

Fig. 3. Fuzzy Logic-based Mobility Controller (FLMC).

describe how to best control the system, under differing operating conditions. Hence, linguistic expressions are needed for the inputs and the output, and the characteristics of the inputs and the output. “Linguistic variables” (that is, symbolic descriptions of what are in general time-varying quantities) are used to describe fuzzy system inputs and output. The linguistic variables take on “linguistic values” that change dynamically over time and are used to describe specific characteristics of the variables; such values are generally descriptive terms such as “low”, “medium” and “high”.

The linguistic variables and values provide us a language to express our ideas about the control decision-making process in the context of the framework established by our choice of FLMC controller inputs and output. In order to determine the linguistic values of the input and output variables, we need to define partitions over the input and output space that will adequately represent the linguistic variables. Since the inputs of the FLMC controller deal with the RSSI and Link-Loss evolution, which is dynamic and time-varying in nature, we need to have as “many” operating regions state partitions as possible, in order to capture as much detail of the dynamics and the nonlinearities of the system plant. However, we also need to keep the controller as simple as possible by not increasing the number of linguistic values state partitions beyond a number, which does not offer significant improvement on the plant performance. The same applies for the output of the FLMC controller, the decision probability.

The model of the FLMC control system, comprising the control rules and the values of the linguistic variables, is obtained through an offline intuitive tuning process that starts from a set of the initial insight considerations and progressively modifies the number of linguistic values of the system until it reaches a level of acceptable performance. The design objective is to keep the controller as simple as possible to start with, and only increase complexity, by adding more linguistic values, if required. An adequate number of linguistic values is needed to describe the nonlinear behavior of the system accurately enough. Adding more rules, as expected, increases the accuracy of the approximation, which yields an improved control performance. But beyond a certain point the improvement is marginal. A formal sensitivity analysis to the choice and number of rules for FLMC is beyond the scope of this paper, but our experimentation has shown that it is not very sensitive.

By choosing the simplest MISO controller, we have avoided the exponential increase of the rule base, and subsequent increase in the complexity of the controller, when the number of input variables increases. The philosophy behind the knowledge base of the FLMC controller is that of being aggressive when the RSSI is low and the Link Loss is high, but on the other hand being able to smoothly respond in the case of adequate conditions in the environment. All other rules can represent intermediate situations, thus providing the control mechanism with a highly dynamic action.

A convenient way to list all possible “IF-THEN” control rules is to use a tabular representation (see Table 1). These rules reflect the particular view and experiences of the

Table 1
FLMC linguistic rules – rule base.

Decision probability		Link Loss rate			
		L ^a	M	H	VH
RSSI	L	LM	M	H	VH
	M	LM	M	H	VH
	H	L	M	H	VH
	VH	L	LM	H	VH

^a Low (L), low-medium (LM), medium (M), high (H), very high (VH).

designer, and are easy to relate to human reasoning processes and gathered experiences.

4.3. Selection of membership functions

We further need to quantify the meaning of the linguistic values using membership functions. The membership functions of the linguistic variables are determined by using an intuitive and pragmatic choice and not an analytic approach (this is one of the reported advantages of fuzzy logic controllers compared to the conventional counterparts). The choice of membership function shape is open. Many shapes are often found in studies (see, e.g. [46]). Due to computational simplicity, we select triangular and trapezoidal shaped membership functions in FLMC control system. These types of shapes are a standard choice used in many industrial applications due to the mathematical simplicity of the expressions representing them. The selected membership functions representing the linguistic values for both the inputs and the output of the FLMC controller are shown in Figs. 4–6. In order to achieve the desired performance, the membership functions are defined based on the real data obtained from long-term testbed evaluation and based on the characteristics of the underlying system. Specifically, the operating regions state partitions are defined based on the observations made of the influence of the two linguistic inputs on attempting to predict the End-to-End loss (as discussed in – Section 3.2 and shown in Fig. 2).

The amount of overlapping between the membership functions areas is significant. The left and right half of the triangular membership functions for each linguistic value is chosen to provide membership overlap with adjacent membership functions. Our method is simple in that the

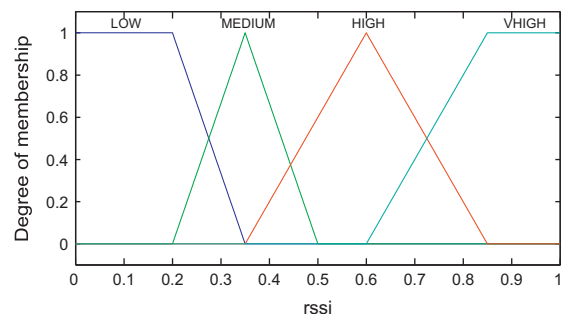

Fig. 4. RSSI linguistic input.

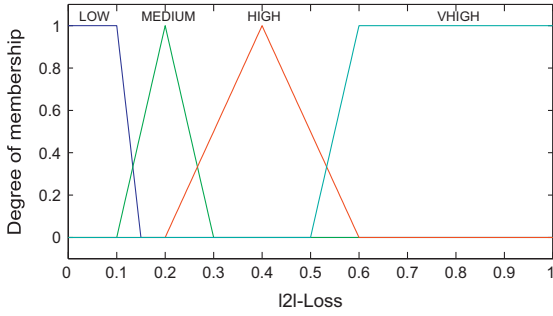

Fig. 5. Link Loss linguistic input.

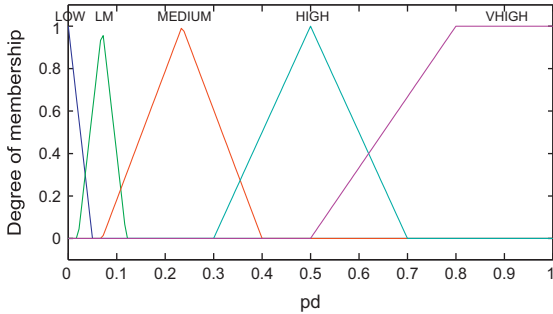

Fig. 6. Decision probability linguistic output.

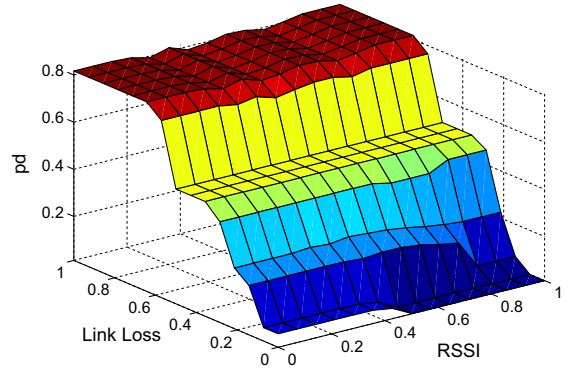

Fig. 7. Decision surface.

sum of the grade of membership of an input value, concerning the linguistic values of a specific input variable, is always one (see Eq. (3)).

$$\sum_{k=1}^m \mu_k(x) = 1 \tag{3}$$

where $\mu_k(x)$ is the membership value of the input value x taken from the membership function of the linguistic value k , ($1 < k < m$, where m is the number of linguistic values of a linguistic variable), of the input variable of concern.

This results in having at most two membership functions overlapping, thus no more than four rules will be activated at any given time. This offers computational simplicity on the implementation of the FLMC controller, a design objective. The overlapping of the fuzzy regions, representing the continuous domain of each control variable, contributes to a well-behaved and predictable system operation; thus the fuzzy system can be very robust.

The nonlinear control-decision surface implemented by the FLMC controller is shaped by the constructed rule base and the linguistic values of the inputs and output variables (see Fig. 7).

This surface represents in a compact way all the information in the fuzzy controller. An inspection of this nonlinear control surface and the linguistic rules shown in Table 1 provides hints on the operation of FLMC. The decision probability behavior under the region of equilibrium (i.e., where RSSI is high and Link Loss is low) is smoothly calculated. On the other hand, the rules are aggressive by

increasing the decision probability sharply in the region beyond the equilibrium point, where the quality starts to get affected and triggering of handoff is required. The dynamic way of calculating the decision probability by the inference process comes from the fact that according to the instantaneous values of the RSSI and Link Loss, a different set of fuzzy rules and so inference apply. Based on these rules and inferences, the decision probability is expected to be more responsive than other conventional solutions, (as for e.g. [51]) due to the human reasoning and the inbuilt nonlinearity.

It is worth remarking that:

1. We have not attempted to optimally tune our fuzzy controller as this can be very demanding (due to the many degrees of freedom associated with the membership functions, the rule base, and the parameters thereof), but more importantly, since further tuning beyond the basic intuitive ideas provides limited returns, as the fuzzy controller performs adequately, as demonstrated in Section 5.
2. In terms of robustness, we have investigated the stability of the proposed system in terms of phase plane analysis. Based on this technique, we show that the states of the system remain within specific bounds (more later, see – Section 5.5).
3. There is no need for a FIE to be built in each sensor MN, thus saving on memory requirements. After the linguistic rules have been found and the linguistic values are defined, the control surface is known and can be stored as a lookup table (size of $n \times n$) for selected sampling points requiring only a few kilobytes of memory in a fuzzy-capable sensor mobile node. In the system examined n is equal to 25, therefore, the lookup table has 625 possible combinations of values. In that way, the memory and computation limitations of sensor networks are taken into account.

Given the above remark, it is thus acceptable to keep the fuzzy inference process as is; however, adaptive tuning of the trigger decision threshold to investigate the tradeoff between increased complexity and improved performance is worthwhile and it can be a subject of future research.

4.4. Handoff decision

At the beginning of each TDMA MAC epoch, the proposed fuzzy based mobility controller finds the current probability value of the trigger decision. If this value is above the trigger decision threshold the node will set its idle slots to scan mode so that to search for a better attachment point. At a first stage the handoff occurs if the following condition is met:

$$S = \left\{ P_j \left| \left([S_N(k) > S_{thresh}] \cap [S_N(k) > S_p + hyst] \right) \cup \left([S_p < S_{thresh}] \cap [S_N(k) > S_p + hyst] \right) \right. \right\} \quad (4)$$

where S is the set containing possible new attachment points, P_j is the possible new attachment point, $S_N(k)$ is the received signal strength from the new attachment point, S_{thresh} is the threshold value, S_p is the received signal strength from the parent node and $hyst$ is the hysteresis value. It is assumed that the hysteresis is equal to one.

In case that more than one new attachment points that meet the above condition exist, then the selection of the best available choice is based on the following formula:

$$\alpha \times RSSI_{last} + \beta \times hops + \gamma \times free_positions \quad (5)$$

where $hops$ is the distance from the sink node and $free_positions$ is the number of free positions that the possible new parent has. Based on prior experimentation the values were set to $\alpha = 0.4$, $\beta = 0.4$, $\gamma = 0.2$.

5. Performance evaluation

This section presents and analyses the results obtained from the evaluation of the mobility solutions in the Petrogal refinery at Sines. Given the focus of our research, we also present a specific experimentation mobility scenario along with specific characteristics of the system and test-bed environment.

5.1. Experimentation scenario

Mobility support in this work has been mainly related to monitoring mobile workers in support of the GINSENG project's Personnel Monitoring scenario. Fig. 8 depicts this application scenario. A worker is tasked with cleaning a storage tank, located in one of the production lines. Surrounding the tank that is being cleaned are usual sensors deployed for other applications, e.g. production monitoring. As the mobile worker moves around the tank, orientation messages are sent from his/her monitoring sensor to the sink, forwarded by intermediate nodes. Orientation is sampled at a frequency of 0.2 Hz.

In order to continuously receive information from the mobile workers a mobility management technique must be implemented so as to enable the handoff between different access points. For example, based on Fig. 8, we have three possible receiver nodes (indicated by the numbers 1, 2 and 3). The mobile worker at the beginning of his/her trip is attached to the receiver node 1. When the mobile worker is near to receiver node 2, the communication link with receiver node 1 is still good; therefore, there is no need to



Fig. 8. Mobility scenario.

Table 2

Personnel safety requirements/assumptions.

Requirements	Definition	Value
Delay	The time bound of data delivery	Data should arrive at the in-field sink in 1 s
Reliability	How important is data delivery	>97%
Mobility	Level of mobility	Mobile workers
Network size	Maximum number of nodes	30
Topology classification	Type of topology	Tree
Hop count	Max number of hops nodes can reside from the sink	4
Time critical traffic direction	What direction are the time-critical flows in?	Upstream
Non-time critical traffic direction	What direction are the non time-critical flows in?	Downstream
Traffic frequency	How often does each node generate a packet	>1 s
Traffic delay bound	Time bound of the time-critical traffic	Upstream 1 s
Number of mobile nodes	The total number of mobile nodes used in our tests	1

handoff. But as the mobile node gets far away from receiver node 1, it has to handoff to a new connection point. Possible new connection points are receiver nodes 2 and 3, but based on the communication quality the mobile worker may prefer to connect with receiver node 3.

Table 2 summarizes the requirements for the Personnel Safety scenario. In terms of the plant network, mobile workers are temporary objects that only exist for a short period of time to complete a specific job. Information on their state must arrive at the control center within few seconds. Although packet losses should be minimized, this application can be tolerant to a small amount of loss. Based on [5,52], the achieved reliability was 99% using fixed nodes with pre-deployed antennas. In our case, we set this requirement to 97%, since we expect higher losses due to the mobility of the nodes.

5.2. System and network setup

As mentioned in the Introduction, this work was implemented and evaluated under the context of the GINSENG project. The general aim of the project was to develop a performance-controlled wireless sensor network that is well suited for situations in which dependable and deterministic operation is needed. For a network to exhibit deterministic behavior, every layer from the application to the hardware/physical layers must act in a predictable manner. To achieve this goal a set of control mechanisms was used in order to ensure deterministic behavior and to allow the network to meet application specific performance targets. The main system characteristics that we assumed in our mobility work are:

1. Use of a TDMA-based MAC [53] protocol. Time is divided into epochs where each epoch has a predefined number of slots. Every node is assigned specific slots to transmit and receive packets. A number of slots is also assigned to each node (at the beginning of each epoch) for processing purposes.
2. The network uses multi-hop communication through a tree-based topology. The tree consists of H layers, where H is equal to the number of hops from the sink. A reasonable small number of nodes ($N < 30$) is used where N is directly proportional to the required communications delay bound; the smaller the required delay, the smaller the N . In the mobility scenario we use a 3–2–1 tree (Fig. 9).
3. Use of Dynamic Topology Control (DTC) [54] techniques. Using DTC each node is attached to the best available tree position during the construction of the network topology. DTC is responsible for Neighbour Discovery, joining and leaving the tree, re-attachment (as in the case of mobility) to the tree, and maintenance of the topology in case of faults.

4. The network is made up of resource constrained embedded systems where the majority of the nodes are deployed in fixed and predetermined positions.
5. The majority of nodes are static with no mobility; however there are cases where nodes appear to be mobile by switching positions in the tree when capacity is available.
6. MN cannot communicate directly with sink nodes except in the case when they are directly connected (logically) to the sink. Thus, the data communication of MN with the sink is accomplished via the other sensor nodes.
7. Nodes report data frequently with relatively high rate (up to once per second) and data must reach the sink within a given time bound T_s .

In addition to the system setup, several steps were performed to prepare the testbed environment. We have deployed wireless sensor network in the refinery, comprised of 12 static nodes and one sink node. Given the physical constraints of the refinery testbed a specific deployment of the static nodes was chosen. The physical environment presented several challenges that impact on performance control and was considered in deployment planning with the most important to be restrictions on potential node locations (and hence topology). Regarding the mobility scenario, we have used the node locations that were provided by the GINSENG project with the main difference the use of DTC. Therefore, the exact placement of a node within a tree is determined first at run-time and it could be different per experiment.

In the GINSENG project, we have selected the Crossbow TelosB as the wireless transmitter. In comparison to alternatives it is relatively simple and low cost. It is an open source design, and easily available worldwide. Finally, it allows use of various I/O and sensing devices, as well as an external antenna, which would be expected to offer higher

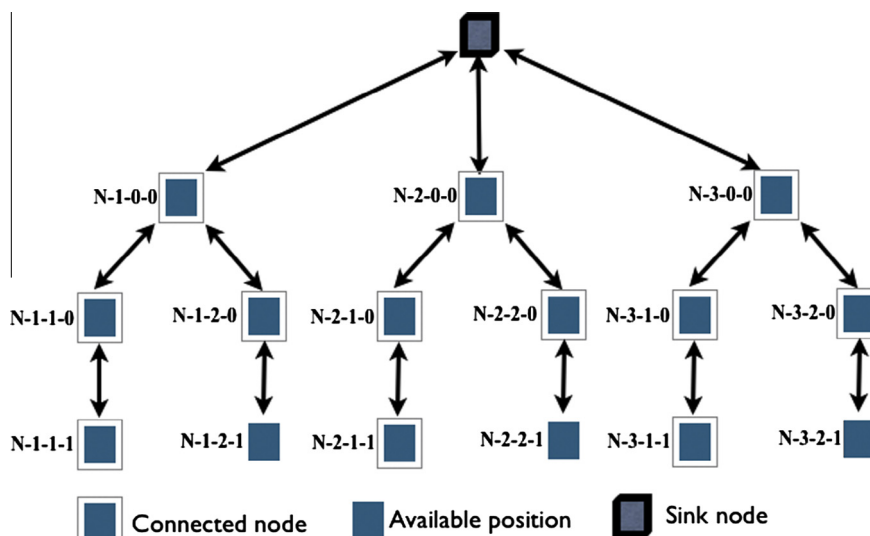

Fig. 9. Tree logical topology.

reliability of radio communication over longer distances. Regarding the MN, we have used the Crossbow TelosB transmitter connected to an external antenna in order to enable the communication between the MN and the tree parent node.

Fig. 10 illustrates the physical topology of the network relative to the control room that is located at the left side border of the testbed. In addition, we have drawn an example logical tree. The testbed dimension is equal to $40\text{ m} \times 30\text{ m}$.

5.3. Evaluation

To evaluate the proposed FLMC algorithm, a number of on-site experiments were performed. We used the GINSENG project infrastructure in order to evaluate our proposed mobility solution. Therefore, any general limitations and characteristics regarding the experiments are the same as in [6]. Regardless of that, the two main limitations related our mobility solution are the following:

1. New attachment point: there is no guarantee that the MN will manage to find a new attachment point.
2. Fuzzy Logic operation: due to the sensor nodes limitations the fuzzy logic controller was designed and run off-line and the decision table was just imported to the flash memory of the node. Therefore, there was no way for the controller to “learn” and adapt its behavior during the operation of the node. Although this could be considered as a limitation, it was also a lesson-learned, since during implementation and testing of the system we discovered that it is not possible to have a full functional fuzzy logic controller running on the MN during the operation.

The MN was introduced in the refinery testbed area and followed different random walks. The duration of the random walks were approximately 20 min. The results shown are the average of ten different walks in the testbed area.

Table 3
Experimental parameters.

Parameters	Value
Tx power	Maximum (0 dBm)
Allowed retransmissions	One software retransmission during the same epoch
MAC layer	GinMAC [53]
MN speed	3 m/s with random stops
Testbed area	$40\text{ m} \times 30\text{ m}$
Max. communication range	20 m
Receiver sensitivity	-94 dBm

Table 3 shows the experimental configuration. We need to mention that the parameter of the communication range was based on real experiments performed during the setup phase of the testbed placement.

Fig. 11 shows the operation of the Fuzzy Logic-based Mobility Controller in a representative experiment. The behavior of the RSSI, Link Loss, and End-to-End Loss was captured so that to conclude if FLMC managed to decrease the packet losses after the triggering was initiated.

Based on Fig. 11 two handoff events happened during the experiment. The first handoff, named Handoff 1, happened when the RSSI value was equal to -80 dBm and the link loss was equal to 18%. As it is observed, after the trigger and the Handoff 1 event the end-to-end packet loss kept decreasing. Despite that, after a short period of time the end-to-end loss increased again, something that led to a new handoff event, named Handoff 2. The RSSI value during the second handoff was equal to -82 dBm where the link loss value was equal to 12%. It is important to note that even though the link loss percentage is lower in this case, the RSSI value is also lower and their combination creates sufficient conditions for a handoff. After the second handoff event, the packet loss had a decreasing trend again.

The proposed FLMC solution was developed based on decentralized information without having any global knowledge about the network condition. Therefore, the

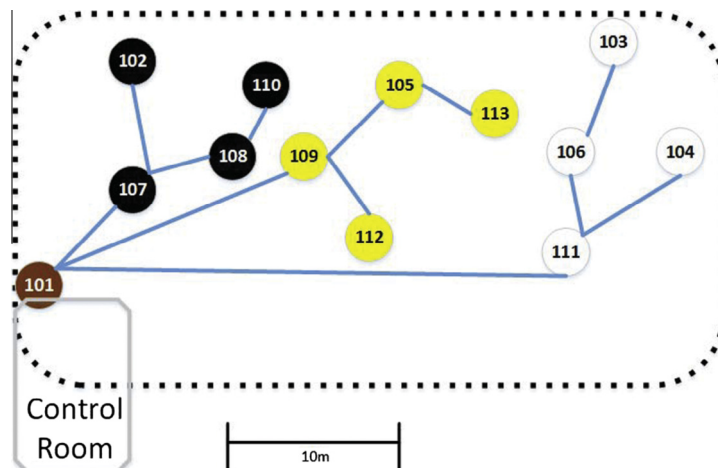

Fig. 10. Node's placement.

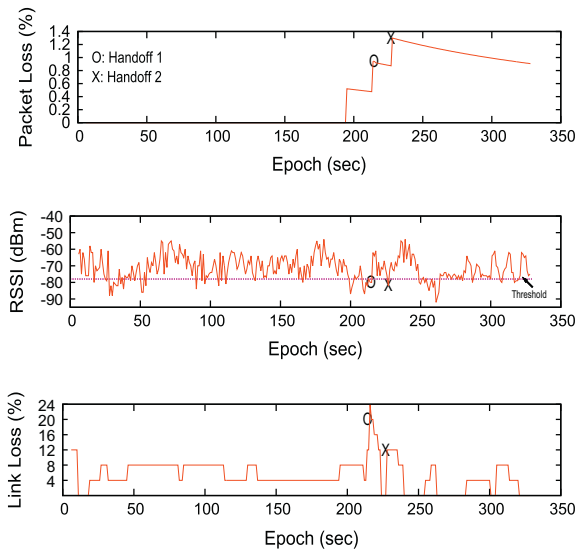

Fig. 11. Fuzzy mobility controller operation.

decision to handoff or not is based on locally available information that the MN has at the specific time and it cannot predict future losses or disconnections. Thus, the performance of the proposed solution can only be determined regarding the packet loss metric, based on the ability to decrease the packet loss after a handoff event and to decrease the total average packet loss comparing to other solutions, like RSSI threshold based ones. Furthermore, a handoff triggering may not result in a re-attachment either because no attachment point exists in the node's vicinity, or because the possible new attachment points do not have performance qualities that satisfy the controller's requirements. In addition, in a number of experiments, it was observed that there are cases at the beginning of the tests where an unnecessary handoff may occur. This is due to the fact that a loss while not many packets have been sent on the link indicates a high Link Loss percentage and wrongfully leads to a handoff. This observation was used to add a delay margin for trigger and handoff at the beginning of each test.

The main advantage of the fuzzy based mobility solution, compared with the RSSI threshold-based solution, is that it manages to decrease the average end-to-end packet loss to 2.45%. Fig. 12 shows the comparison of the mobility solutions.

It is obvious that in the case of no mobility management (No Handoff) and in the case of the RSSI threshold-based solution the packet loss is high. This is due to the unpredictability of the environment and the RSSI behavior. On the other hand, using the fuzzy mobility solution, those effects were reduced and a packet loss value within the 3% limit was achieved. Fig. 12 shows the breakdown of the causes of packet loss. The losses are distinguished into two categories: the first category is when the MN has the ability to communicate with the parent node but some communication (bad link) or system losses occurred, and the second category is when the node is located in an area where it is not covered by the communication range of any

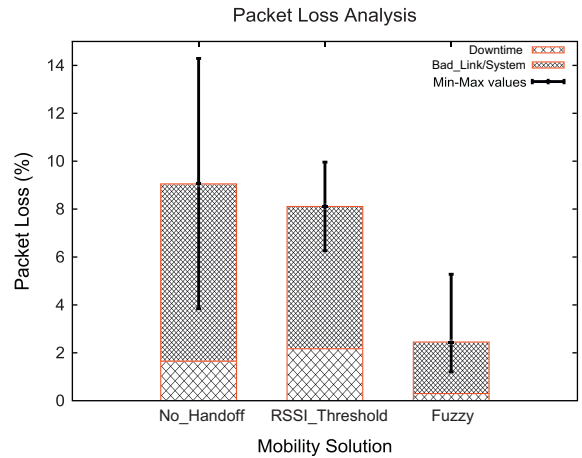

Fig. 12. Average end-to-end packet loss comparison.

other node (downtime). The majority of the losses in all the cases are due to system or bad links. On the other hand, the existence of packet losses that occurred due to uncovered areas provides a hint that a better placement of the fixed nodes in the network or the addition of more fixed nodes could help minimizing the packet loss.

Further to the End-to-End packet loss, Fig. 13 shows the power consumption comparison of the mobility solutions.

It is clear that both solutions consume more energy compared with the scenario where the MN is moving in the testbed without mobility management. This is due to the fact that in order to find a better position more scanning slots are required. Despite that, the mobility management is required in our scenario, therefore, there is not any logic to compare mobility solutions with no-handoff solution. Comparing the two mobility solutions, one can observe that the fuzzy solution performs better than the RSSI threshold solution with a total energy decrease of 10.78%. The reason of that, is the fact that the fuzzy solution performs fewer triggers and therefore, has less scanning slots. In addition, it is worth noting that the transmission energy consumption of the RSSI threshold based solution is increased compared with the fuzzy based solution. This is due to the fact that the increased packet loss leads to more retransmissions of data packets.

The total power consumption was calculated considering the following power elements: Transmission power (Tx), Reception Power (Rx), Flash Write Power (FW), Flash Read (FR), CPU Active (CPUact) and CPU Sleep (CPUsl).

Based on [55], the radio and external flash device have significantly higher power consumption than the microcontroller. The flash consumes power only when the microcontroller writes to or reads from the flash. Similarly, the radio consumes power only when the radio is transmitting or listening. The most important thing to note is that the radio consumes a significant amount of power when it is listening for radio traffic. Using the results shown in Fig. 13 the reception power contributes up to 90% to the total power consumption. Therefore, it is crucial to minimize reception slots. A solution to this overhead could be an adaptive way of selecting the threshold value. In such

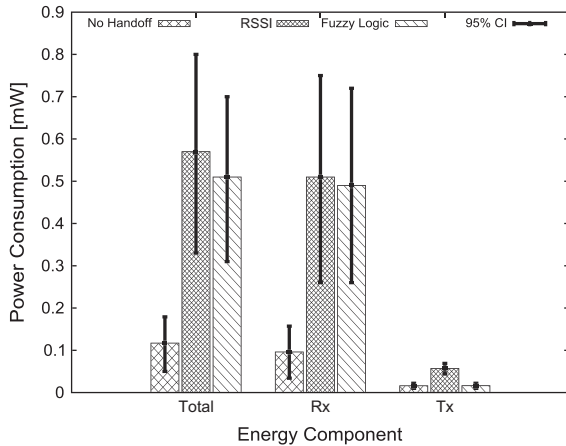

Fig. 13. Power consumption comparison.

way, the adaptive thresholding module will use information from the network performance in order to adapt the threshold, accordingly. For example, since there is no guarantee that the MN will manage to find a better attachment point while in scanning mode, the adaptive module could record the number of scanning slots and if these slots are above a predefined value it will force the MN to exist the scanning mode. To gauge the impact on lifetime, if one were to assume the use of standard 3000 mA h batteries, the MN would have a life expectancy of 175 days.

Moreover, based on Fig. 14 the fuzzy mobility solution has increased the effective triggers (ratio of successful handoff triggers) from 4.15% to 8.1% by decreasing at the same time the average total number of triggers from 108.5 to 18.5. The reduction of the unnecessary triggers leads to the reduction of the energy consumption.

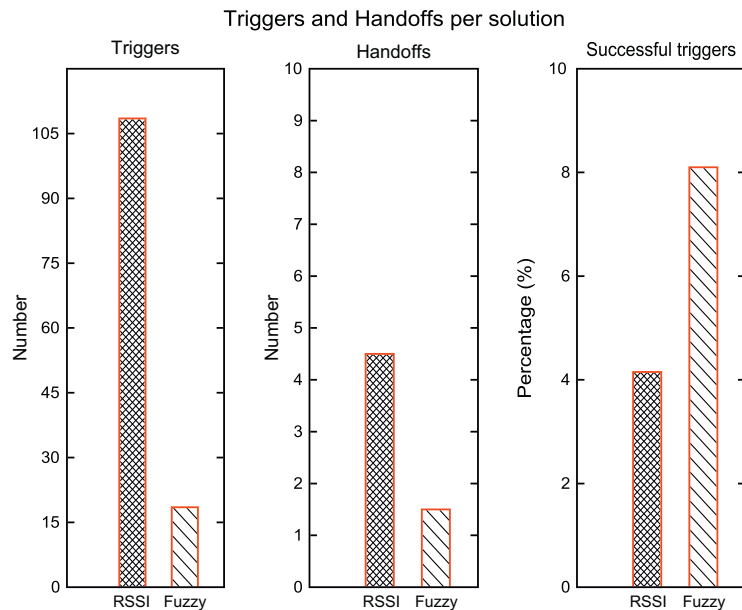

Fig. 14. Triggers and handoffs for mobility solutions.

Furthermore, the packet delivery delay of both mobility solutions (Fig. 15) is inside the limit of 1 s, whereas in the case there is no mobility management this delay is over 1 s. The reason is that the packets are kept in the queue for longer time due to the fact that the MN could be outside the transmission range of its parent node.

Concluding, it is obvious that the fuzzy logic based mobility solution performs better in comparison with the RSSI-based mobility solution, and it fulfills some basic performance requirements that were set for the specific application environment (e.g. end-to-end packet loss less than 3% and an end-to-end delivery delay of no more than 1 s).

5.4. Comparison with conventional single metric-based solutions

Based on the related work presented in Section 2 different approaches have been proposed to control the handoff procedure in several types of networks. Despite that, none of these solutions was implemented and evaluated under real testbed setting. In addition, none of these solutions could be directly compared with our proposed solution, since the settings and the configurations were different. Therefore, in order to be able to compare our approach and conclude about the suitability and applicability of it, we proceeded with the implementation and the evaluation of the most used approach that is the use of the RSSI metric. In addition to that, we implemented handoff solutions [51] that were based on single metrics approach as the Link Loss, Burst losses and averaging (Simple Moving Average (SMA) and Estimated Weighted Moving Average (EWMA)) techniques regarding the RSSI and the Link Loss. We this approach we can exploit the advantages and the drawbacks of the proposed solution. The evaluation of these metrics was done using COOJA [56] simulator and the radio

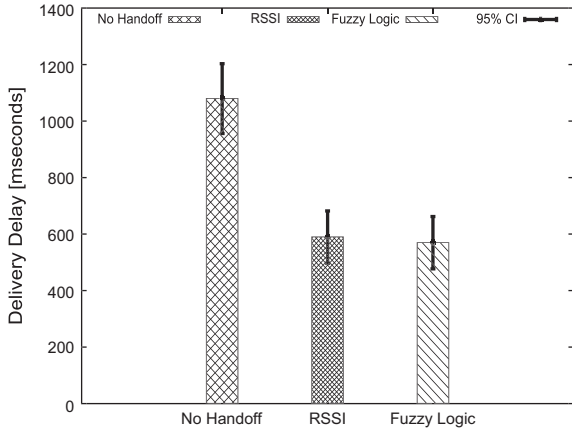

Fig. 15. Packet delivery delay.

Table 4

Simulation parameters.

Simulation time	2000 s
Testbed size	40 × 30 m
Max. transmission range	20 m
Number of simulations	100
Number of fixed/mobile nodes	13/1
Mobility model/Waypoint paths	Random Waypoint/10
Radio propagation model	GINSENG model [45]
Packet rate	1 packet/3 s

propagation model that we proposed in [45] that managed to “mimic” in COOJA with high probability the refinery behavior. The simulation parameters are shown in Table 4. Since the number of experiments and the MN paths were different from the on-site testbed experiments in this section we present only the results obtained from the simulation environment.

In these evaluations we introduce also a new metric that it is called “on-time triggering” which indicates the percentage of the successful triggers when two or more end-to-end packets were lost. Table 5 presents an overall comparison of the Fuzzy Logic-based solution with the single-based solutions in terms of End-to-End packet losses, power consumption, and on-time triggering.

The first important observation is that the Fuzzy Logic-based solutions on average have higher on-time triggering percentage which means that we can consider Fuzzy

Table 5

Experimental results.

Solution	Packet loss (%)	Total power consumption (mW)	Number of triggers	On-time (%)
RSSI threshold, −78 dBm	4.1	0.39	5.28	32.4
EWMA RSSI, $t = 5, a = 0.33$	3.47	0.368	0.77	17.92
SMA RSSI, $n = 10$	3.45	0.37	0.22	22.2
Link Loss, threshold 1%	2.42	3.11	2.25	45.3
EWMA Link Loss 10%, $t = 5, a = 0.33$	2.41	0.79	2.88	21.6
SMA Link Loss 30%, $n = 10$	2.43	0.80	4.12	38.9
Burst losses, $n = 3$	4.3	0.39	1.7	37.4
Fuzzy, $P_{threshold} = 0.06$	2.1	1.8	14.2	61.4
Fuzzy, $P_{threshold} = 0.16$	2.4	1.3	5.6	54.2
Fuzzy, $P_{threshold} = 0.18$	2.5	0.66	2.1	39.4

Logic-based triggering as the best triggering solution. The second important observation is the fact that the Fuzzy Logic-based solution with $P_{threshold} = 0.06$ shows the minimum End-to-End packet loss and the higher on-time triggering percentage. Despite that, compared to the majority of the other solutions it shows increased power consumption. However, compared to the Link Loss solution with threshold 1% it presents 42% less power consumption. The common characteristic of both solutions is the low threshold values. Based on these observations, the next step will be to find a way to minimize the power consumption overhead of the fuzzy-based solutions. This could be achieved by implementing an adaptive way to select the threshold value based on the current behavior of the system. Therefore, we consider that even though the specific $P_{threshold}$ thresholds, shown in Table 5, present a better performance compared to the other solutions, an adaptive threshold selection would improve the performance more and especially in decreasing the power consumption and increasing the on-time triggering.

5.5. System stability and boundedness

Our objective has been to control the handoff procedure in order to choose the best attachment point, which, in turn, ensures low End-to-End packet losses. Based on the plot of Fig. 2 low End-to-End packet losses can be achieved by minimizing the link loss and maximizing the RSSI. The considered control system is shown schematically in Fig. 16.

It can be observed that the Fuzzy Logic Controller provides the switching logic, which at any time chooses the “best” attachment point in the sense that it is the one that minimizes the Link Loss and increases the RSSI. The output of the fuzzy controller is a value that, compared with a predefined threshold, indicates whether the MN will initiate the triggering procedure. When the triggering starts the MN searches for a new attachment point. It decides to handoff if the new attachment point (if any) fulfills the handoff criteria. The stability analysis of the proposed control system is difficult due to the complexity of the considered plants, which makes the modeling procedure intractable. The absence of a validated model of the plant has motivated our fuzzy control design. However, we evaluate the stability and boundedness of our system using phase plane analysis, which is common in similar cases. We consider the RSSI and the Link Loss to be the states

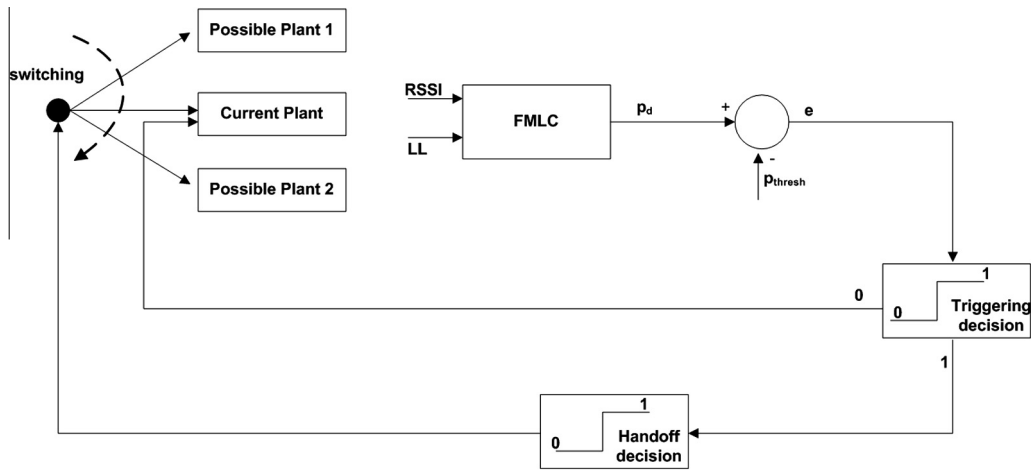

Fig. 16. Fuzzy logic-based system.

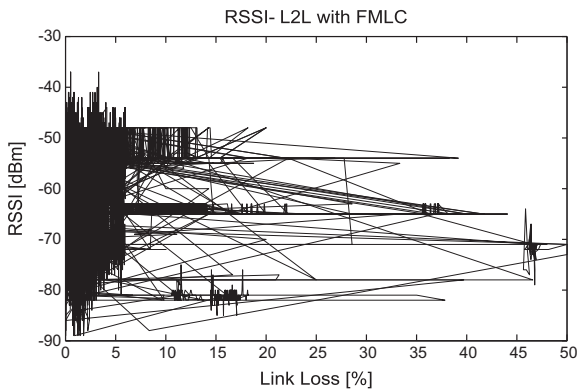

Fig. 17. RSSI versus LL using FLMC.

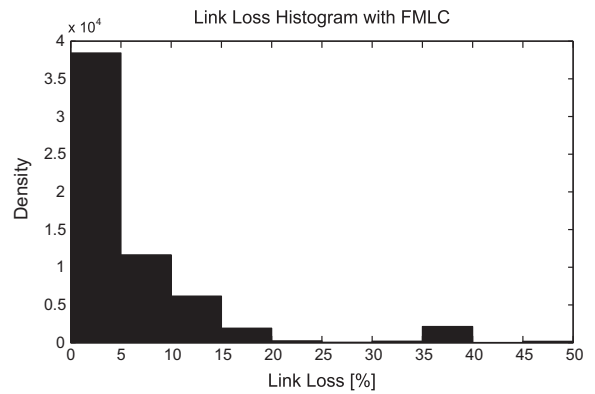

Fig. 19. Link Loss density with FLMC.

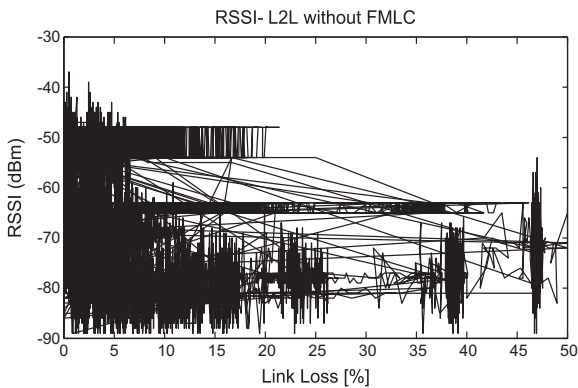

Fig. 18. RSSI versus LL without FLMC.

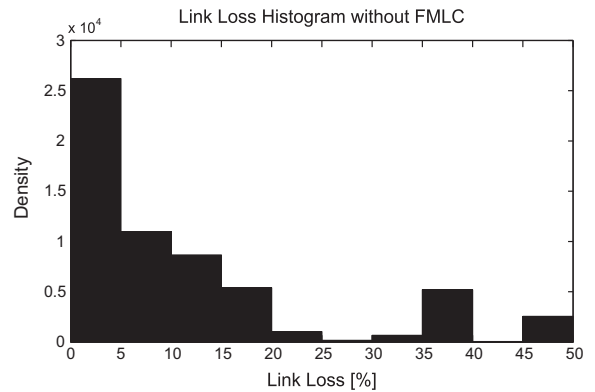

Fig. 20. Link Loss density without FLMC.

of our system and we construct plots of RSSI versus the Link Loss using simulations. Due to the inherently random nature of the system, the output does not converge to a single equilibrium point, however, the states of the system remain within specific bounds. In Figs. 17 and 18 we show plots of the RSSI versus the Link Loss, with and without the FLMC.

We observe that in both cases the states remain bounded with a minimum value equal to 0% and a maximum value equal to 50%. Since stability in terms of boundedness of the considered signals is achieved in both cases, the benefit gained of using the FLMC is that the controlled system increases the probability of operating in a region

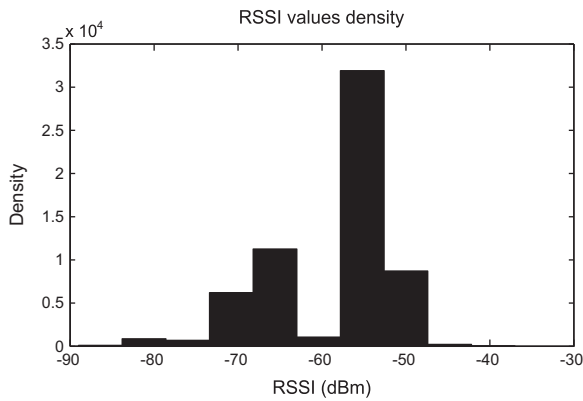

Fig. 21. RSSI density with FLMC.

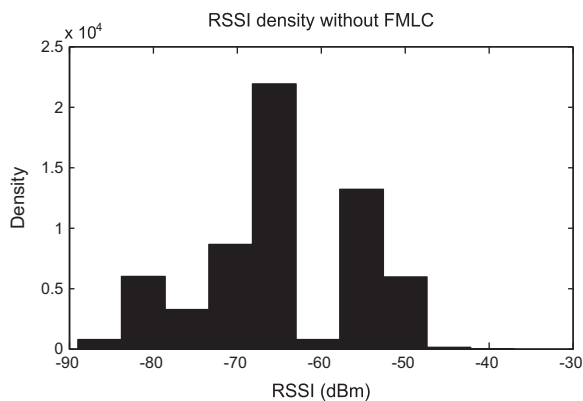

Fig. 22. RSSI density without FLMC.

Table 6
Link Loss statistics comparisons.

Solution	Min	Max	Mean	Median	St. deviation
FLMC	0	50	6.05	3.1	7.8
Without FLMC	0	50	11.4	7.1	12.7

Table 7
RSSI statistics comparisons.

Solution	Min	Max	Mean	Median	St. deviation
FLMC	-89	-37	-57	-54	7.6
Without FLMC	-89	-37	-64	-65	9.85

which ensures high RSSI and low Link Loss values, which has been our initial objective. This is evident in Figs. 17 and 18, which demonstrate that when the FLMC is used, areas with low Link Loss and high RSSI are more densely populated. In order to make this even clearer, we plot density histograms of the Link Loss and RSSI values both for the controlled and the uncontrolled systems, which are shown in Figs. 19–22. We observe that the use of the FLMC controller manages to increase the density of the low Link

Loss values and at the same time increase the density of the high RSSI values.

The non-zero density values at high link loss values are due to the fact that there is no guarantee that the MN will manage to find a new attachment point to handoff. In such a case, the MN will show increased losses.

In addition to the above, Table 6 depicts statistics of the Link Loss that support the claim that FLMC managed to operate in regions with lower Link Loss and higher RSSI than the non-controlled system. As we can observe, the mean value without FLMC is 11.4% while with FLMC it is at 6.05%. In addition, the FLMC system presents lower standard deviation.

Regarding the RSSI, we observe in Table 7 that FLMC manages to operate in higher regions, something that is evident by the mean and standard deviation statistics.

6. Conclusion

In this work a holistic approach to designing and implementing a mobility management solution in WSN, to support mobile workers inside an industrial environment, was taken. The proposed mobility solution efficiently maintains the connectivity of the mobile node by controlling the handoff procedure. In the design of this solution network state variables which are readily available at all sensor MNs were used. Thus, the proposed mechanism is generically applicable to any industrial WSN or testbed with mobility requirements. This work moves beyond single metric (RSSI-based) mobility solutions by proposing an intelligent controller, based on fuzzy logic, in order to help sensor MNs to control handoffs with a need for performance guarantees. The applicability of the proposed mobility solution was validated in a real testbed scenario inside the industrial environment of an oil refinery. The results clearly show that the proposed mobility solution outperforms the RSSI-based mobility solution in terms of packet loss, packet delivery delay, energy consumption, and ratio of successful handoff triggers. As future work, an adaptive way of selecting the handoff trigger threshold could be helpful in reducing the power consumption of the Fuzzy Logic-based mobility solution.

Acknowledgments

The research leading to these results has received funding from the European Community Seventh Framework Programme (FP7/2007–2013) under Grant Agreement n224282. We acknowledge all GINSENG partners for creating the final version of the GINSENG platform. The authors would like to thank Jose Manuel do O of Petrogal for helping us run the on-site experiments.

References

- [1] J. Caffery, G. Stuber, Overview of radiolocation in CDMA cellular systems, *Commun. Magaz., IEEE* 36 (4) (1998) 38–45.
- [2] J. Song, S. Han, A. Mok, D. Chen, M. Lucas, M. Nixon, W. Pratt, WirelessHART: applying wireless technology in real-time industrial process control, in: Proceedings of the 2008 IEEE Real-Time and Embedded Technology and Applications Symposium, RTAS '08, 2008, pp. 377–386.

- [3] Anna N. Kim, Fredrik Hekland, Stig Petersen, Paula Doyle, When HART goes wireless: understanding and implementing the WirelessHART standard, in: IEEE International Conference on Emerging Technologies and Factory Automation (ETFA), IEEE, 2008, pp. 899–907.
- [4] ISA-100.11a-2009, Wireless Systems for Industrial Automation: Process Control and Related Applications, 2009.
- [5] GINSENG – Performance Control in Wireless Sensor Networks, European Community Seventh Framework Programme (FP7), 2012.
- [6] T. O'Donovan, J. Brown, F. Buesching, A. Cardoso, J. Cecilio, J. D'O, Pedro Furtado, P. Gil, A. Kugel, W.-B. Poettner, U. Roedig, J. Sa-Silva, R. Silva, C. Sreenan, V. Vassiliou, T. Voigt, L. Wolf, Z. Zinonos, The GINSENG system for wireless monitoring and control: design and deployment experiences, *Trans. Sensor Netw. ACM* 10 (1) <<http://www.ict-ginseng.eu/documents.php?idfolder=10>>.
- [7] C. Perkins, D. Johnson, J. Arkko, Mobility Support in IPv6, RFC 3775, 2004.
- [8] H. Soliman, C. Castelluccia, K. El-Makri, L. Bellie, Hierarchical Mobile IPv6 Mobility Management (HMIPv6), RFC 4140, 2005.
- [9] R. Koodli, Fast Handovers for Mobile IPv6, RFC 4068, 2005.
- [10] S. Gundavelli, K. Leung, V. Devarapalli, K. Chowdhury, B. Patil, Proxy Mobile IPv6, RFC 5213, 2008.
- [11] M. Durvy, J. Abeillé, P. Wetterwald, C. O'Flynn, B. Leverett, E. Gnoske, M. Vidales, G. Mulligan, N. Tsiftes, N. Finne, A. Dunkels, Making sensor networks IPv6 ready, in: Proceedings of the 6th ACM Conference on Embedded Network Sensor Systems, SenSys '08, 2008.
- [12] IPv6 over Low power WPAN, 6LoWPAN Working Group, 2010.
- [13] H. Kim, C.S. Hong, T. Shon, A lightweight NEMO protocol to support 6LoWPAN, *ETRI J.* 30 (5) (2008) 685–695.
- [14] G. Bag, H. Mukhtar, S. Shams, K.H. Kim, S.-W. Yoo, Inter-PAN mobility support for 6LoWPAN, in: Third International Conference on Convergence and Hybrid Information Technology, 2008, ICCIT '08, vol. 1, 2008, pp. 787–792.
- [15] G. Bag, M.T. Raza, K.-H. Kim, S.-W. Yoo, LoWMob: intra-PAN mobility support schemes for 6LoWPAN, *Sensors* 9 (7) (2009) 5844–5877.
- [16] K. Jin, H. Choong, O. Koji, A routing scheme for supporting network mobility of sensor network based on 6LoWPAN, in: S. Ata, C. Hong (Eds.), *Managing Next Generation Networks and Services*, vol. 4773, 2007, pp. 155–164.
- [17] R. Silva, J.S. Silva, An Adaptation Model for Mobile IPv6 Support in lowPANs, draft-silva-mip6-00, 2009.
- [18] A. Jara, M. Zamora, A. Skarmeta, HWSN6: Hospital Wireless Sensor Networks Based on 6LoWPAN Technology: Mobility and Fault Tolerance Management, in: International Conference on Computational Science and Engineering, 2009, CSE '09, vol. 2, 2009, pp. 879–884.
- [19] M. Ha, D. Kim, S.H. Kim, S. Hong, Inter-MARIO: A fast and seamless mobility protocol to support inter-pan handover in 6LoWPAN, in: Global Telecommunications Conference (GLOBECOM 2010), 2010, pp. 1–6.
- [20] M. Islam, M. Hassan, E.-N. Huh, Sensor proxy mobile IPv6 (SPMIPv6) – a framework of mobility supported IP-WSN, in: 13th International Conference on Computer and Information Technology (ICIT), 2010, 2010, pp. 295–299.
- [21] Z. Zinonos, V. Vassiliou, Inter-mobility support in controlled 6LoWPAN networks, in: GLOBECOM Workshops (GC Wkshps), 2010, pp. 1718–1723.
- [22] W. Ye, J. Heidemann, D. Estrin, An energy-efficient MAC protocol for wireless sensor networks, in: Proceedings 21st International Annual Joint Conference of the IEEE Computer and Communications Societies, New York, NY, USA, 2002.
- [23] T. van Dam, K. Langendoen, An adaptive energy-efficient MAC protocol for wireless sensor networks, in: Proceedings of the 1st International Conference on Embedded Networked Sensor Systems, SenSys '03, 2003, pp. 171–180.
- [24] J. Polastre, J. Hill, D. Culler, Versatile low power media access for wireless sensor networks, in: Proceedings of the 2nd International Conference on Embedded Networked Sensor Systems, SenSys '04, 2004, pp. 95–107.
- [25] M. Buettner, G.V. Yee, E. Anderson, R. Han, X-MAC: a short preamble MAC protocol for duty-cycled wireless sensor networks, in: Proceedings of the 4th International Conference on Embedded Networked Sensor Systems, SenSys '06, 2006, pp. 307–320.
- [26] H. Pham, S. Jha, Addressing mobility in wireless sensor media access protocol, in: Proceedings of the Intelligent Sensors, Sensor Networks and Information Processing Conference, 2004, 2004, 2004, pp. 113–118.
- [27] L. Bing, Y. Ke, Z. Lin, Z. Huimin, MAC performance and improvement in mobile wireless sensor networks, in: Eighth ACIS International Conference on Software Engineering, Artificial Intelligence, Networking, and Parallel/Distributed Computing, 2007, SNPD 2007, vol. 3, 2007, pp. 109–114.
- [28] A. Gonga, O. Landsiedel, M. Johansson, MobiSense: power-efficient micro-mobility in wireless sensor networks, in: International Conference on Distributed Computing in Sensor Systems and Workshops (DCOSS), 2011, 2011, pp. 1–8.
- [29] H. Ramamurthy, B. Prabhu, R. Gadh, A. Madni, *Wireless industrial monitoring and control using a smart sensor platform*, *Sens. J., IEEE* 7 (5) (2007) 611–618.
- [30] P. Marichamy, S. Chakrabarti, S. Maskara, Overview of handoff schemes in cellular mobile networks and their comparative performance evaluation, in: IEEE VTS 50th Vehicular Technology Conference, 1999, VTC 1999 – Fall, vol. 3, 1999, pp. 1486–1490.
- [31] K. Srinivasan, P. Levis, RSSI is under appreciated, in: Proceedings of the Third Workshop on Embedded Networked Sensors (EmNets), 2006.
- [32] K. Srinivasan, M.A. Kazandjieva, S. Agarwal, P. Levis, The beta-factor: measuring wireless link burstiness, in: Proceedings of the 6th ACM Conference on Embedded Network Sensor Systems (SenSys), 2008, 2008, pp. 29–42.
- [33] H. Fotouhi, M. Zuniga, M. Alves, A. Koubaa, P. Marrón, Smart-HOP: a reliable handoff mechanism for mobile wireless sensor networks, in: 9th European Conference on Wireless Sensor Networks (EWSN), 2012, 2012, pp. 131–146.
- [34] K. Srinivasan, P. Dutta, A. Tavakoli, P. Levis, Understanding the causes of packet delivery success and failure in dense wireless sensor networks, in: 4th International Conference on Embedded Networked Sensor Systems (SenSys), 2006, 2006, pp. 419–420.
- [35] Y. Wu, J. Stankovic, T. He, S. Lin, Realistic and efficient multi-channel communications in wireless sensor networks, in: 27th Conference on Computer Communications INFOCOM 2008, 2008, pp. 1193–1201.
- [36] W. Zhang, Handover decision using fuzzy MADM in heterogeneous networks, in: Wireless Communications and Networking Conference, 2004, WCNC 2004, vol. 2, IEEE, 2004, pp. 653–658.
- [37] H. Fotouhi, M. Alves, A. Koubaa, N. Baccour, On a reliable handoff procedure for supporting mobility in wireless sensor networks, in: the 9th International Workshop on Real-Time Networks RTN'2010 in Conjunction with the 22nd Euromicro International Conference on Real-Time Systems (ECRTS 2010), Brussels, Belgium, 2010.
- [38] P.M.L. Chan, R. Sheriff, Y. Hu, P. Conforto, C. Tocci, *Mobility management incorporating fuzzy logic for heterogeneous a IP environment*, *Commun. Magaz., IEEE* 39 (12) (2001) 42–51.
- [39] H. Liao, L. Tie, Z. Du, A vertical handover decision algorithm based on fuzzy control theory, in: First International Multi-Symposiums on Computer and Computational Sciences, 2006, IMSCS '06, vol. 2, 2006, pp. 309–313.
- [40] L. Barolli, A. Durresi, F. Xhafa, A. Koyama, A fuzzy-based handover system for wireless cellular networks: a case study for handover enforcement, in: Proceedings of the 2nd International Conference on Network-Based Information Systems, NBIS '08, 2008, pp. 212–222.
- [41] L. Barolli, J. Anno, F. Xhafa, A. Durresi, A. Koyama, *A context-aware fuzzy-based handover system for wireless cellular networks and its performance evaluation*, *J. Mob. Multimed.* 4 (3) (2008) 241–258.
- [42] Z. Zinonos, R. Silva, V. Vassiliou, J. Silva, Mobility solutions for wireless sensor and actuator networks with performance guarantees, in: 18th International Conference on Telecommunications (ICT), 2011, 2011, pp. 406–411.
- [43] R. Silva, Z. Zinonos, J. Sa Silva, V. Vassiliou, Mobility in WSNs for critical applications, in: 2011 IEEE Symposium on Computers and Communications (ISCC), 2011, pp. 451–456.
- [44] Z. Zinonos, V. Vassiliou, S-GinMob: soft-handoff solution for mobile users in industrial environments, in: 2011 International Conference on Distributed Computing in Sensor Systems and Workshops (DCOSS), 2011, pp. 1–6.
- [45] Z. Zinonos, V. Vassiliou, T. Christofides, Radio propagation in industrial wireless sensor network environments: from testbed to simulation evaluation, in: 7th ACM Workshop on Performance Monitoring and Measurement of Heterogeneous Wireless and Wired Networks (PM2HW2N), 2012, 2012, pp. 125–132.
- [46] K.M. Passino, S. Yurkovich, *Fuzzy Control, first ed., Addison-Wesley Longman Publishing Co., Inc., Boston, MA, USA, 1997.*
- [47] L.A. Zadeh, Outline of a new approach to the analysis of complex systems decision processes, *IEEE Trans. Syst., Man Cybernet. SMC-3* (1) (1973) 28–44.

- [48] E. Mamdani, Application of fuzzy algorithms for control of simple dynamic plant, *Proc. Inst. Electr. Eng.* 121 (12) (1974) 1585–1588.
- [49] A. Pitsillides, Y.A. Sekercioglu, G. Ramamurthy, Effective control of traffic flow in ATM networks using fuzzy explicit rate marking (FERM), *IEEE J. Select. Areas Commun.* 15 (2) (1997) 209–225.
- [50] C. Chrysostomou, A. Pitsillides, Y. Sekercioglu, Fuzzy explicit marking: a unified congestion controller for best-effort and diff-serv networks, *Comput. Netw.* 53 (5) (2009) 650–667.
- [51] Z. Zinonos, V. Vassiliou, C. Chrysostomou, Handoff triggering for wireless sensor networks with performance needs, in: 18th IEEE Symposium on Computers and Communications (IEEE ISCC 2013), Split, Croatia, 2013.
- [52] C.-J.M. Liang, J. Liu, L. Luo, A. Terzis, F. Zhao, RACNet: a high-fidelity data center sensing network, in: Proceedings of the 7th ACM Conference on Embedded Networked Sensor Systems, SenSys '09, 2009, pp. 15–28.
- [53] P. Suriyachai, J. Brown, U. Roedig, Time-critical data delivery in wireless sensor networks, in: R. Rajaraman, T. Moscibroda, A. Dunkels, A. Scaglione (Eds.), *Distributed Computing in Sensor Systems*, vol. 6131, 2010, pp. 216–229.
- [54] Z. Zinonos, V. Vassiliou, C. Ioannou, M. Koutroullos, Dynamic topology control for WSNs in critical environments, in: 4th IFIP International Conference on New Technologies, Mobility and Security (NTMS), 2011, 2011, pp. 1–5.
- [55] J. Polastre, R. Szewczyk, D. Culler, Telos: enabling ultra-low power wireless research, in: Proceedings of the 4th International Symposium on Information Processing in Sensor Networks, IPSN '05, 2005.
- [56] J. Eriksson, F. Österlind, N. Finne, N. Tsiotes, A. Dunkels, T. Voigt, R. Sauter, P.J. Marrón, COOJA/MSPSim: interoperability testing for wireless sensor networks, in: Proceedings of the 2nd International Conference on Simulation Tools and Techniques, Simutools '09, 2009, pp. 27:1–27:7.



Mr. Zinon Zinonos completed his undergraduate studies at CEID (Computer Engineering and Informatics Department, University of Patras) in 2005 and his M.Sc. studies at the Department of Computer Science at the University of Cyprus in 2007. Currently, he is a Ph.D. candidate at the Department of Computer Science of the University of Cyprus. Furthermore, his research interests include Sensor Networks, Mobile Networks (MIPv4, MIPv6, Ad Hoc), Wireless Communications (3G/4G cellular wireless networks) and Quality of Service (QoS in IPv6 networks). Since May 2013, he is a member of the KIOS research center at UCY.



Dr. Chrysostomos Chrysostomou has received a B.Eng. in Electronic & Electrical Engineering, with First Class Honours, and M.Sc. in Telematics (Telecommunications & Software), from the University of Surrey, UK, in 1998 and 1999 respectively. He received the Doctor of Philosophy (Ph.D.) degree in Computer Science from the University of Cyprus in 2006.

Since October 2008, he has been with the Department of Computer Science and Engineering at Frederick University, at the rank of Lecturer. He is the Coordinator of the Networks and Systems academic domain unit within the Department, and the Lead person of the Computer

Networks Research Unit (CNetRU), as well as the Director of the Networks Laboratory (NETLAB). Prior to his current appointment, he served in a number of positions in the Department of Computer Science at the University of Cyprus from September 1999 until September 2008. In particular, he worked as a research associate and a special scientist in several research projects, and further, he worked as a Special Teaching Staff, and also as a Visiting Lecturer.

Currently he serves as one of the two Cyprus Delegates of the Management Committee of the European Concerted Research Action IC0906 ("Wireless Networking for Moving Objects"). He actively serves as a member of several Technical Program Committees of international scientific conferences and workshops, and also as a referee in international scientific journals and conferences. He is involved in the organization of international conferences (Local Organizing Chair of MUM2010 and IWCMC2012/2014, and Publication Chair of ICT2011 and MedHoc-Net2012). He is a member of IEEE and ACM.

His research interests include Quality of Service (QoS) provisioning in fixed/wired and mobile/wireless networks by developing mainly congestion control techniques based on computational intelligence. Recently, of prime concern is the development of efficient algorithms for mobility support in wireless sensor networks. In addition, his current work focuses in the development of adaptive, QoS-aware, secured control mechanisms in vehicular ad hoc networks. Further, of major importance is the application of computer networking principles and techniques in the field of high performance computer architecture (network-on-chip architectures).



Dr. Vasos Vassiliou is an Assistant Professor at the Computer Science Department of the University of Cyprus. He is also the Vice Director of the Networks Research Laboratory. He has served as a Lecturer (2005–2011) and as a Visiting Lecturer (2004–2005) at the same department and as an Assistant Professor at the Computer Science Department of the University of Nicosia (2002–2004). Dr. Vassiliou holds a Ph.D. from the Georgia Institute of Technology, Atlanta, Georgia, USA, with specialization in Telecommunications

and Mobile Network protocols. He is a graduate of the Higher Technical Institute (HND 1993) and the University of South Florida (B.Sc. 1997) both in Electrical Engineering. His graduate studies were sponsored by a partial CASP scholarship from the Cyprus Fulbright Commission at the Georgia Institute of Technology (M.Sc., 1999 and Ph.D., 2002 in Electrical and Computer Engineering). He has worked as a researcher at the Georgia Institute of Technology and held internship positions with BellSouth Mobility DCS and Nortel Networks during his graduate studies. He has published several articles in Journals and International Conferences and has co-authored a number of book chapters. His research interests include Next Generation Network Architectures (IPv6, MPLS), Mobile Networks (Mobile IP, Mobile MPLS, Ad Hoc and Sensor Networks), Wireless Communications (Protocol enhancements for 3G/4G cellular networks) and QoS and Traffic Engineering for computer and telecommunication networks. He is a member of IEEE, ACM, IET (former IEE), the Cyprus Scientific and Technical Chamber (ETEK), and the Cyprus Computer Society (CCS). He is a Chair of the PWSN (Performance Control in Wireless Sensor Networks) series of workshops (since 2011) and participates as a Technical Program Committee member in several international conferences, such as GLOBECOM, VTC, PIMRC, and European Wireless. He is also an Associate Editor of the Journal of Telecommunication Systems (Springer).